

Ray Tracing Basics

Reading

Required:

- Foley *et al.*, 16.12

Optional (recommended):

- Hearn & Baker, 14.6
- Glassner, chapter 1

Geometric optics

- Modern theories of light treat it as both a wave and a particle.
- We will take a combined and somewhat simpler view of light - the view of **geometric optics**.
- Here are the rules of geometric optics:
 - Light is a flow of photons with wavelengths. We'll call these flows "light rays."
 - Light rays travel in straight lines in free space.
 - Light rays do not interfere with each other as they cross.
 - Light rays obey the laws of reflection and refraction.
 - Light rays travel from the light sources to the eye, but the physics is invariant under path reversal (reciprocity)

Ray Tracing

- A term from optics
- A “physical” simulation of the particle theory of light
- In the 1960s, ray tracing seemed like a great idea, but nobody could do it well enough to beat cheaper image synthesis methods.
- These days, we can follow the simulation deeply enough to get great results!
- But there are some visual phenomena that ray tracing **cannot do**.

Why Ray Tracing?

- **Ray casting:**
 - for each pixel in the projection plane, find the object visible at that pixel and
 - color that pixel according to the object color
- What does this model miss? What if the object is reflective?

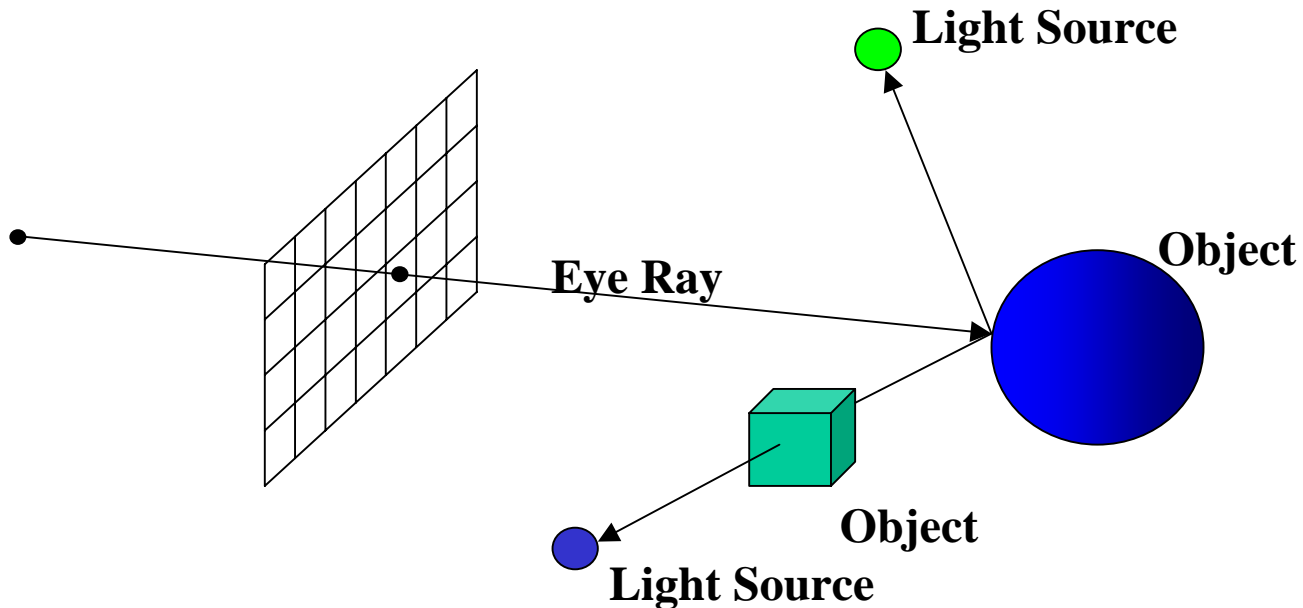

Forward Ray Tracing

- Rays emanate from light sources and bounce around in the scene.
- Rays that pass through the projection plane and enter the eye contribute to the final image.

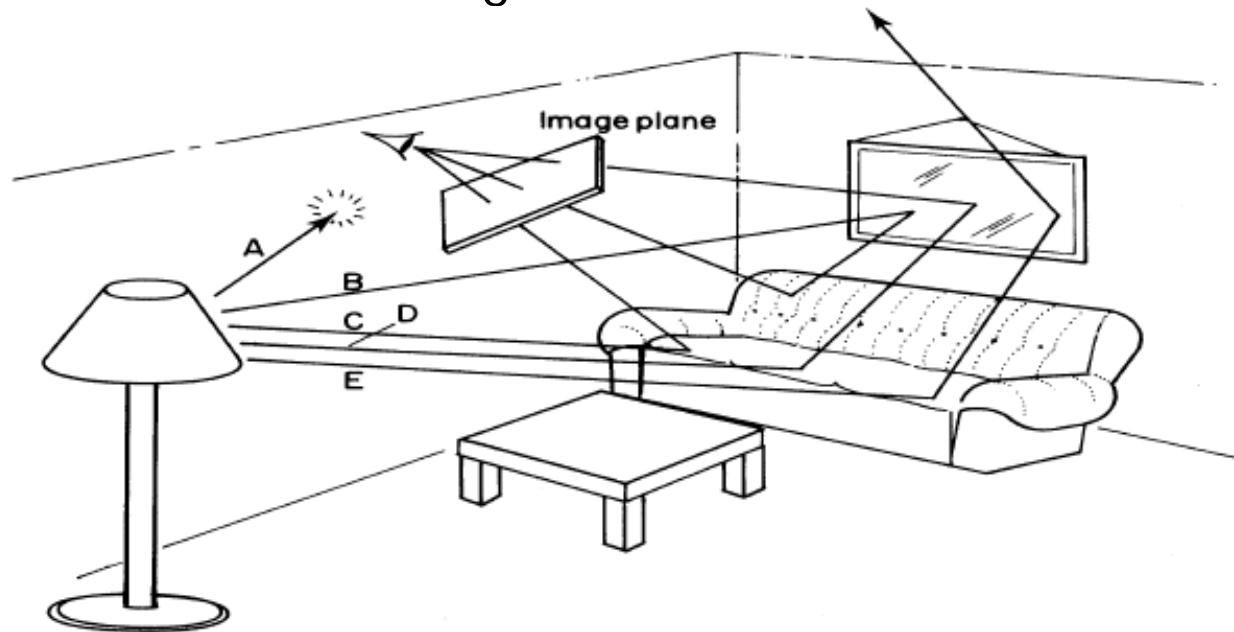

- What's wrong with this method?

Backward Ray Tracing

- (Efficiency!) Rather than propagating rays indiscriminately from light sources, we'd like to ask "which rays will definitely contribute to the final image?"
- We can get a good approximation of the answer by firing **rays from the eye**, through the projection plane and into the scene
 - These are the paths that light must have followed to affect the image

Precursors to ray tracing

Local illumination

- Cast one eye ray, then shade according to light

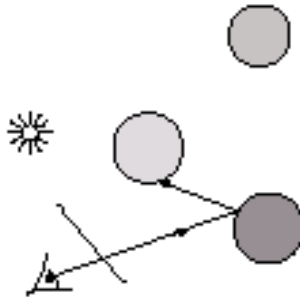

Appel (1968)

- Cast one eye ray + one ray to light

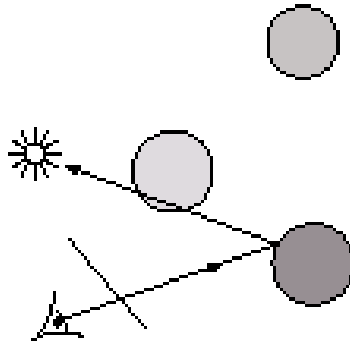

Whitted ray-tracing algorithm

- In 1980, Turner Whitted introduced ray tracing to the graphics community.
 - Combines backward ray tracing + rays to light
 - Recursively traces rays

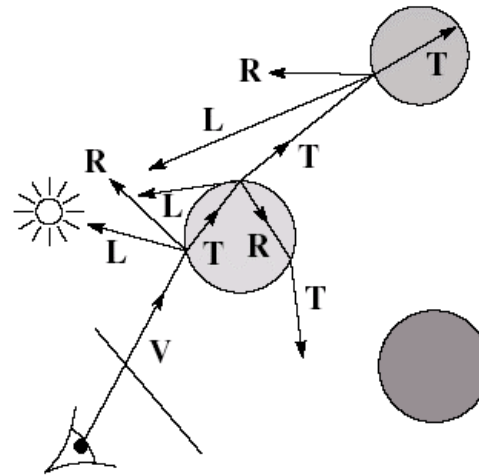

Algorithm:

1. For each pixel, trace a **eye (primary) ray** in direction **V** to the first visible surface (or ray casting).
2. For each intersection, trace **secondary rays**.
 - Shadow rays in directions L_i to light sources.
 - Reflected ray in direction **R**.
 - Refracted ray or transmitted ray in direction **T**.

Kinds of (Backward) Rays

- Three kinds of rays
 - Shadow rays
 - Reflection rays
 - Transparency rays

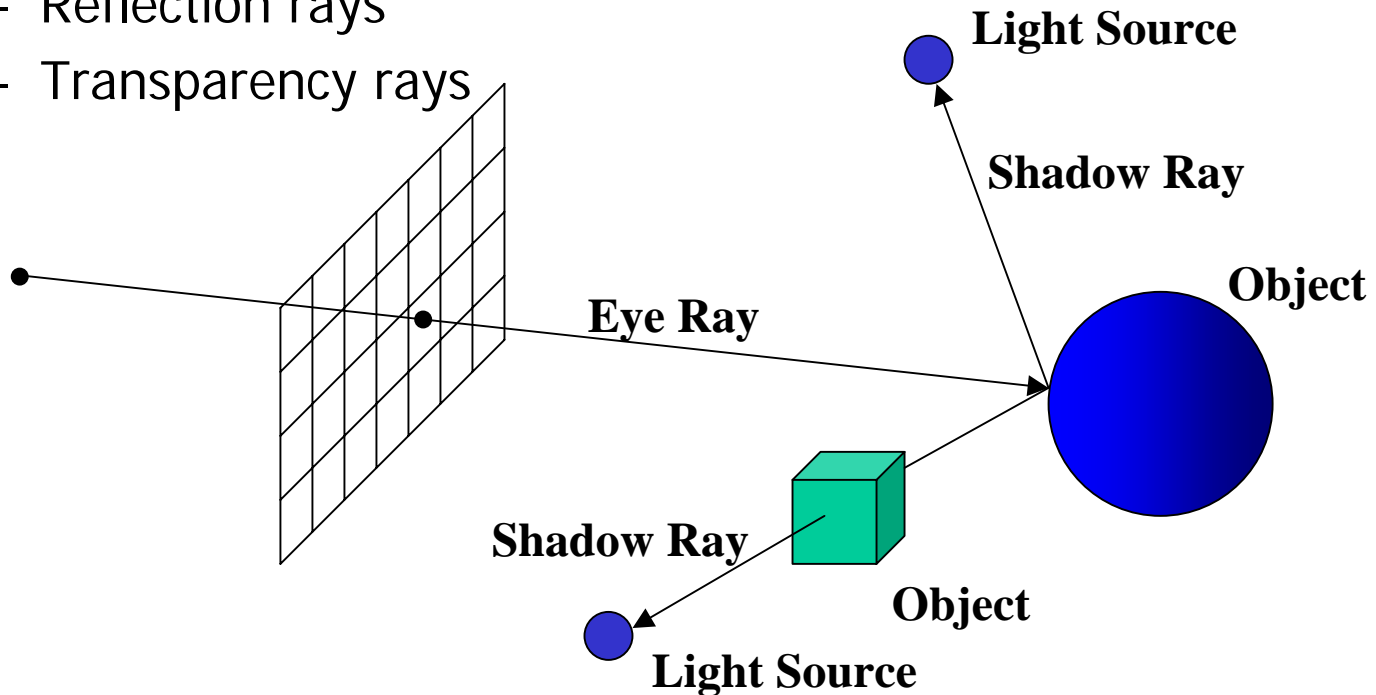

Kinds of (Backward) Rays

- A ray that leaves the eye and travels out to the scene is called a **primary ray**.
- When a ray hits an object, we spawn three new (backward) rays to collect light that must contribute to the incoming primary ray:
 - **Shadow rays** to light sources, used to attenuate incoming light when applying the shading model
 - **Reflection rays**, which model light bouncing off of other surfaces before hitting this surface
 - **Transparency rays**, which model light refracting through the surface before leaving along the primary ray

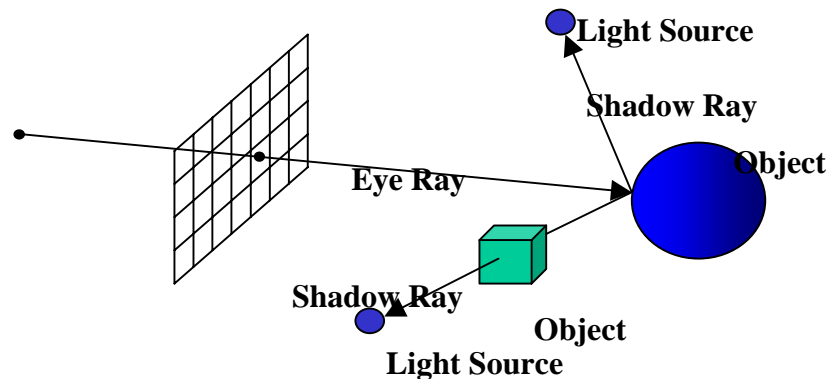

- Shadow rays stop at light sources, but reflection and transparency rays behave just like primary rays!

Whitted algorithm

Let's look at this in stages:

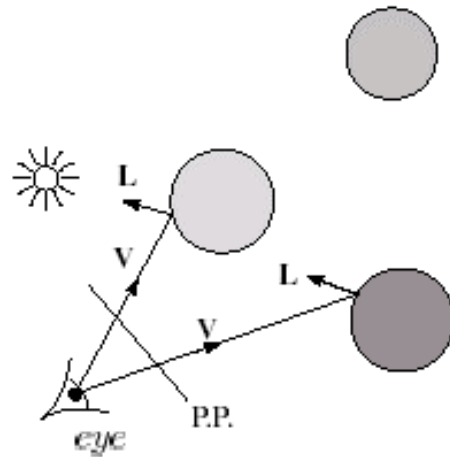

Primary rays

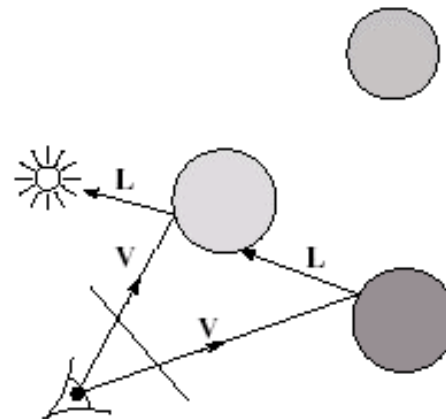

Shadow rays

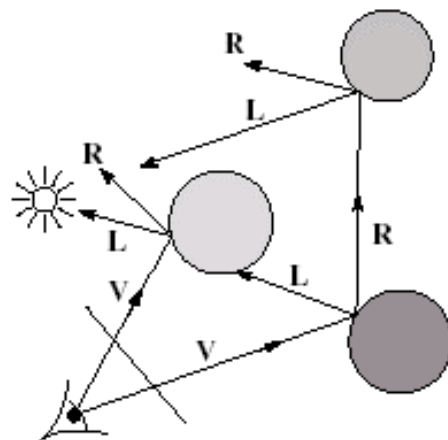

Reflection rays

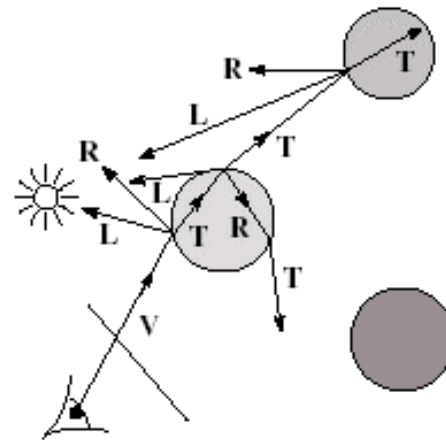

Refracted rays

Example of Ray Tracing

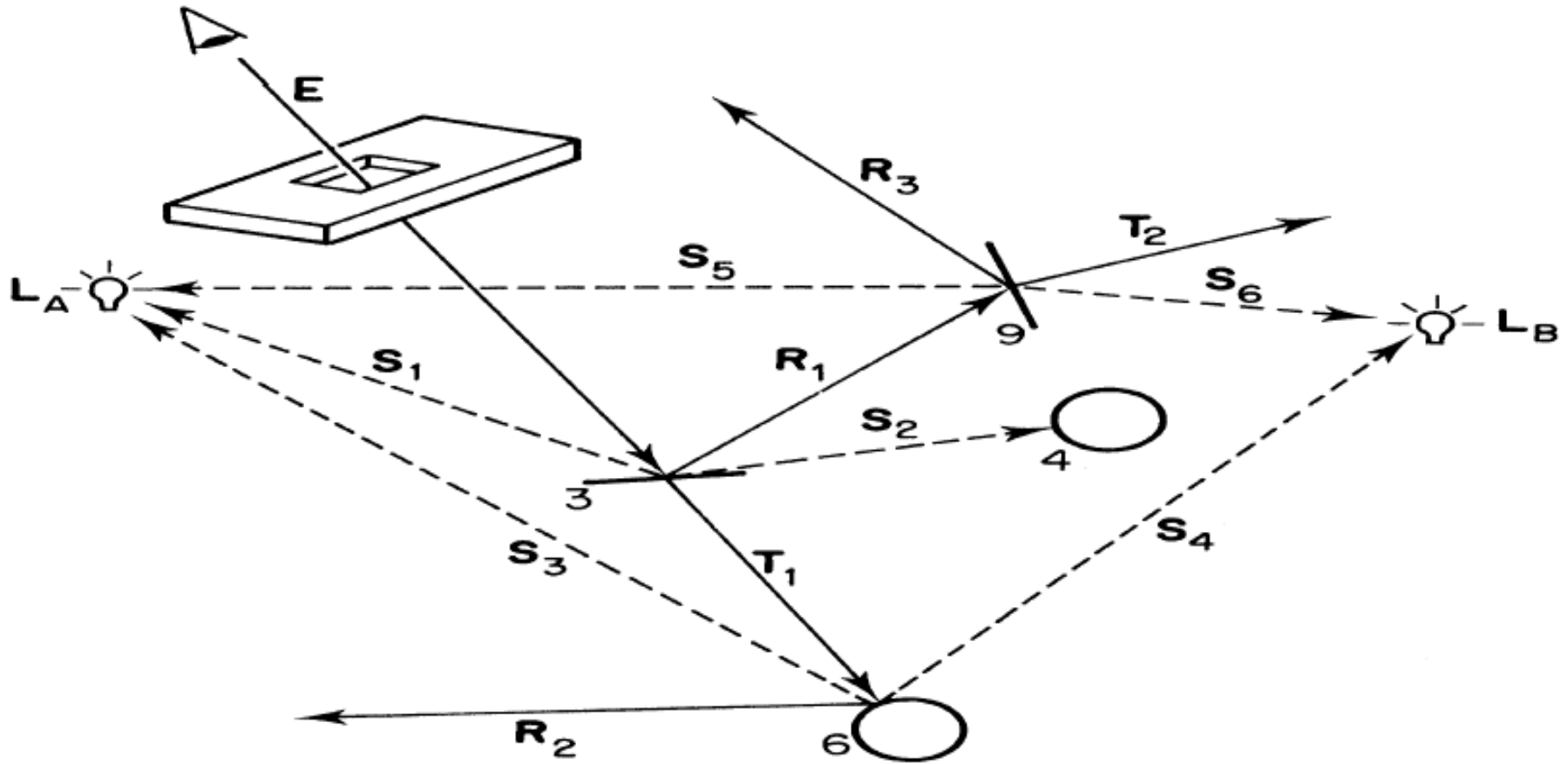

Ray Tree

- A primary ray hits a surface and spawns reflection and transparency rays. Those rays may hit surfaces and spawn their own rays, etc.
- We can represent this process schematically using a **ray tree**:

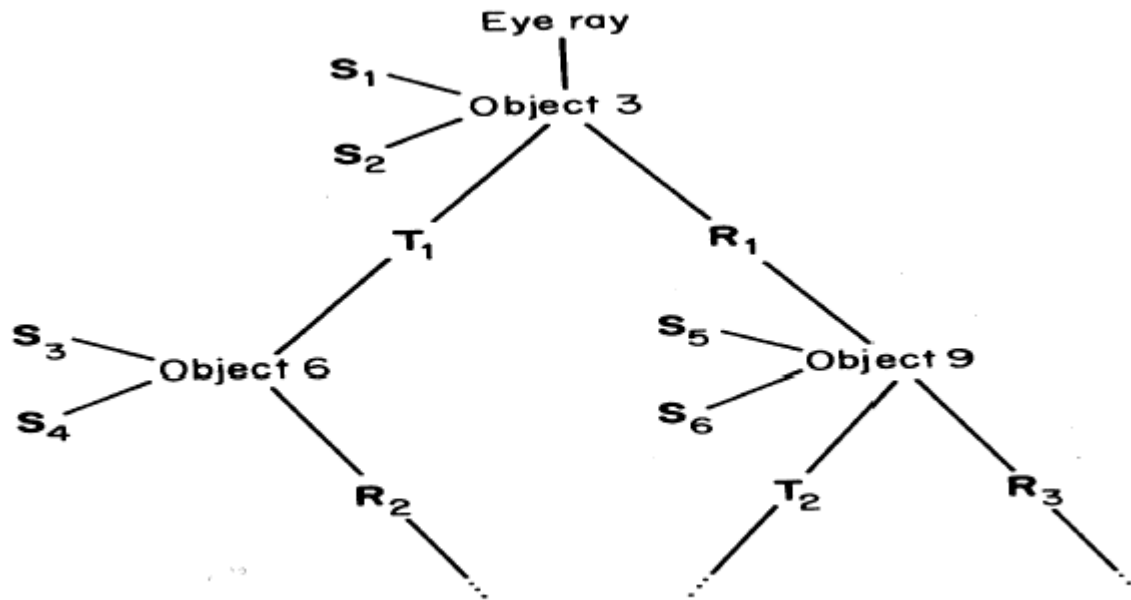

Controlling Tree Depth

- Ideally, we'd spawn child rays at every object intersection forever, getting a "perfect" color for the primary ray.
- In practice, we need heuristics for bounding the depth of the tree (i.e., recursion depth)

Shading

- A ray is defined by an origin \mathbf{p} and a unit direction \mathbf{d} and is parameterized by t :

$$\mathbf{p} + t \mathbf{d}$$

- Let $I(\mathbf{P}, \mathbf{d})$ be the intensity seen along that ray. Then:

$$I(\mathbf{P}, \mathbf{d}) = I_{\text{direct}} + I_{\text{reflected}} + I_{\text{transmitted}}$$

where

- I_{direct} is computed from the Phong model
 - $I_{\text{reflected}} = k_r I(\mathbf{Q}, \mathbf{R})$
 - $I_{\text{transmitted}} = k_t I(\mathbf{Q}, \mathbf{T})$
- Typically, we set $k_r = k_s$ and $k_t = 1 - k_s$ if there is no diffuse reflection.

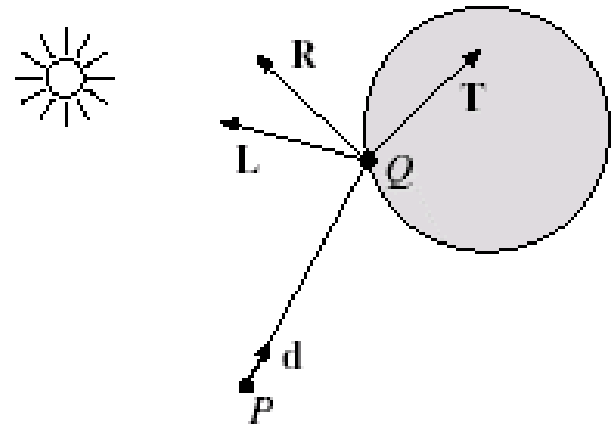

Reflection and transmission

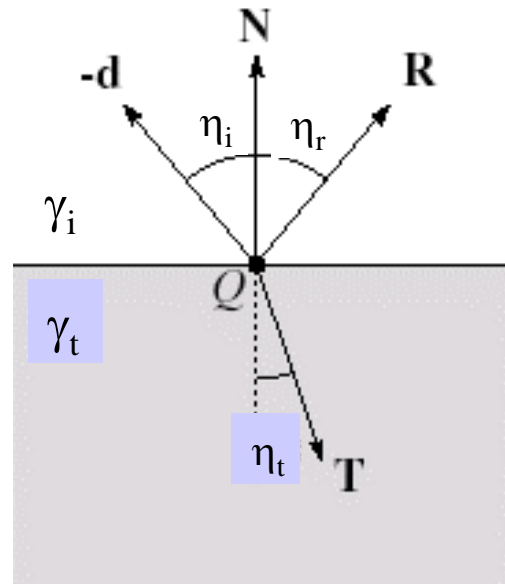

- Law of reflection: $\eta_i = \eta_r$
- Snell's law of refraction: $\gamma_i \sin \eta_i = \gamma_t \sin \eta_t$
where γ_i and γ_t are **indices of refraction**.

Total internal reflection

- The equation for the angle of refraction can be computed from Snell's law.
- What happens when $n_i > n_t$?
- When θ_t is exactly 90 deg, we say that θ_i has achieved "critical angle" θ_c .
- For $\theta_i > \theta_c$, no rays are transmitted, and only reflection occurs, a phenomenon known as "total internal reflection" or TIR.

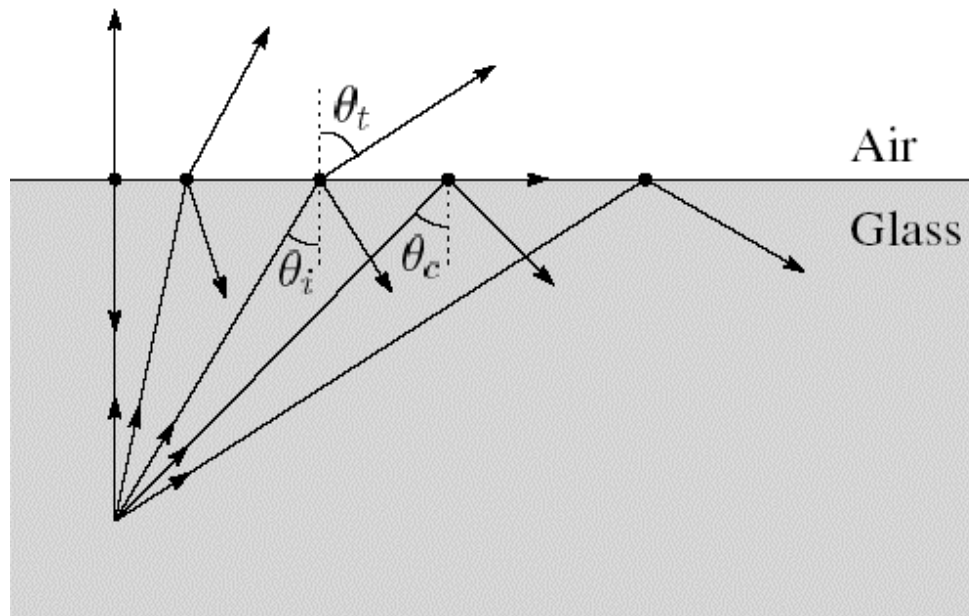

A Recursive Ray Tracer

- Now, put everything together...

Ray tracing pseudocode

- We build a ray traced image by casting rays through each of the pixels:

```
function tracelImage (scene):  
    for each pixel (i,j) in image  
         $S = \text{pixelToWorld}(i,j)$   
         $P = \mathbf{COP}$   
         $\mathbf{d} = (S - P) / \|S - P\|$   
         $I(i,j) = \text{traceRay}(\text{scene}, P, \mathbf{d})$   
    end for  
end function
```

Ray tracing pseudocode (cont)

```
function traceRay(scene, P, d):  
    (t, N, mtrl)  $\leftarrow$  scene.intersect (P, d)  
    Q  $\leftarrow$  ray (P, d) evaluated at t  
    I = shade(  
        Q, N, mtrl  
    )  
    R = reflectDirection(  
        Q, N, mtrl  
    )  
    I  $\leftarrow$  I + mtrl.kr * traceRay(scene, Q, R)  
    if ray is entering object then  
        ni = index_of_air  
        nt = mtrl.index  
    else  
        ni = mtrl.index  
        nt = index_of_air  
    if (notTIR (  
        ni, nt, Q, N  
    )) then  
        T = refractDirection (  
            Q, N, ni, nt  
        )  
        I  $\leftarrow$  I + mtrl.kt * traceRay(scene, Q, T)  
    end if  
    return I  
end function
```

Shade

- Next, we need to calculate the color returned by the *shade* function.

function *shade*(mtrl, scene, Q , \mathbf{N} , \mathbf{d}):

$I \leftarrow \text{mtrl.k}_e + \text{mtrl.k}_a * \text{scene} \rightarrow I_a$

for each light source ℓ **do**:

$\text{atten} = \ell \rightarrow \text{distanceAttenuation}(\quad) *$

$\ell \rightarrow \text{shadowAttenuation}(\quad)$

$I \leftarrow I + \text{atten} * (\text{diffuse term} + \text{spec term})$

end for

return I

end function

Shadow attenuation

- Computing a shadow can be as simple as checking to see if a ray makes it to the light source.
- For a point light source:

```
function PointLight::shadowAttenuation(scene, P)
```

```
    d = (l.position - P).normalize()
```

```
    (t, N, mtrl) ← scene.intersect(P, d)
```

```
    Q ← ray(t)
```

```
    if Q is before the light source then:
```

```
        atten = 0
```

```
    else
```

```
        atten = 1
```

```
    end if
```

```
    return atten
```

```
end function
```

- Q: What if there are transparent objects along a path to the light source?

Epsilons!!

- Due to finite precision arithmetic, we do not always get the exact intersection at a surface.
- Q: What kinds of problems might this cause?
- Q: How might we resolve this?

Intersecting with xformed geometry

- In general, objects will be placed using transformations. What if object being intersected were transformed by a matrix M ?
- Apply M^{-1} to the ray first and intersect in object (local) coordinates!
- The intersected normal is in object (local) coordinates. How do we transform it to world coordinates?

Summary

- Understanding of basic ray tracing concepts
- Forward vs. backward tracing
- Classification of rays
- The ray tree
- Terminating recursion